

The JA-111R BUS interface for JA-100 wireless devices

The JA-111R is a BUS module of the JABLOTRON 100 system. It serves for radio communication with wireless devices. Up to 3 modules can be used in the system to extend RF signal coverage. The product should be installed by a trained technician with a valid certificate issued by an authorised distributor.

Installation

The module should be installed at appropriate place inside the building where it is not influenced by any other radio devices. If it is necessary to install the module near bigger metal objects or near electronic appliances or switchboards, keep a minimum distance of 2 m away from them. The module can be placed directly inside the control panel, however it works the best when placed at least 2 m from the control panel. When more radio modules are installed in the system, they should not be placed next to each other (in an open area a minimum 10 m distance and inside the building a minimum of one wall and 5 m must be between them).

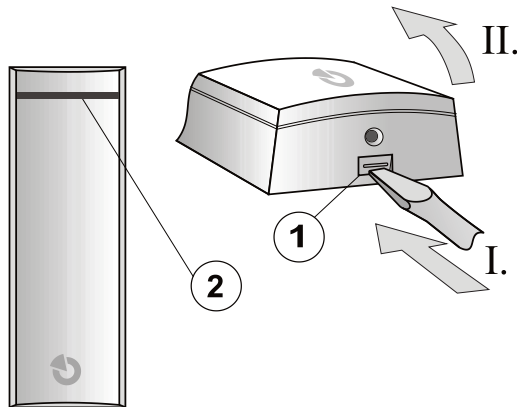

Figure 1: 1 – cover tab; 2 – LED indicator

1. Open the cover by pressing the tab (1).
2. Prepare holes for the BUS cable (12) on the rear housing part (9) and put the BUS cables through.
3. Screw the rear housing part (9). One of the screws always has to be screwed through the tampering segment (10).

When connecting the module to the BUS, always switch the power off.



To set the module to comply with security grade 2 use F-Link SW, Parameters tab and the option "Perform EN50131-1". (See the JA-10xK control panel installation manual)

4. Unplug the BUS connector (7) from the PCB and connect the BUS cables.
5. Plug the connector back into the radio module PCB.
6. The BUS cable has to be placed in the space behind the cable separator (11), then close the cover of the module.
7. Proceed according to the control panel installation manual.

Basic procedure:

- a. When the device is switched on, the yellow LED (2) starts flashing repeatedly to indicate that the module has not been enrolled yet.
- b. Go to the **F-Link** software, select the required position in the **Devices** tab and launch the enrollment mode by clicking on the **Enroll** option.
- c. Click on **Add new BUS devices**, select the radio module and by a double press confirm enrolling – the yellow LED (2) goes off.

Notes:

- For better identification of a particular device during the enrollment procedure via the F-Link SW, we recommend removing the label with the production code (3) before you close the cover and sticking it on an installation list with a note about the device's location.
- The radio module can also be enrolled by closing its cover when **Enrollment mode** is activated or by entering its production code (3) in the F-Link software. All numbers under the bar code shall be entered (example: 1400-00-0000-0001).

Setting of module properties

The module properties can be set in the **Devices** tab of the **F-Link** software. At the module position, click on the **Internal settings** option to open a dialogue window where you can set the following parameters:

Activation indicated by LED: The default setting is that the module indicates communication with wireless devices by a red LED. This indication can be disabled.

RF jamming level: It is disabled as a default. However, it can be set to two levels – **low** (interference lasts longer than 30 s per one minute) and **high** (interference lasts longer than 10 s per 20 s). When the detection is enabled, the system is able to report a fault by communication band interference / RF jamming.

Enrollment signal: When this option is used in the software, the module sends an enrollment signal (intended only for wireless devices with a built-in receiver, for example JA-150N).

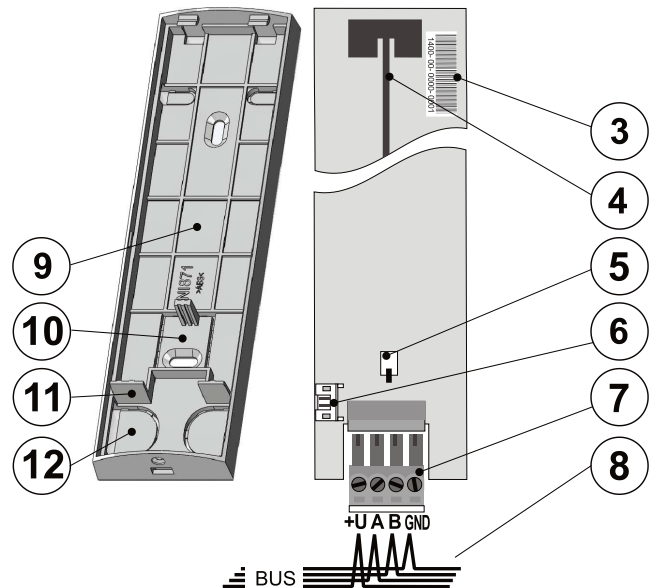

Figure 2: 3 – production code; 4 – antenna; 5 – tamper contact; 6 – BUS connector; 7 – plug and play BUS terminal; 8 – BUS cable; 9 – rear housing part; 10 – segment for detection of tampering; 11 – cable separator; 12 – holes for BUS cable

Technical specifications

Power	from control panel BUS 12 V DC (9 ... 15 V)
Current consumption in standby mode	35 mA
Current consumption for cable selection	80 mA
Radio communication	868.1 MHz
Dimensions	43 x 160 x 23 mm
Weight	70 g
Classification	Security grade 2, ACE type B
according to	EN 50131-1, EN 50131-3, EN 50131-5-3
Environmental class	II. Indoor general (according to EN 50131-1)
Operational temperature range	-10 °C to +40 °C
Complies with	ETSI EN 300 220, EN 50130-4, EN 55022, EN 60950-1
Can be operated according to	ERC REC 70-03
Certification body:	Trezor Test s.r.o.



JABLOTRON ALARMS a.s. hereby declares that the JA-111R is in compliance with the essential requirements and other relevant provisions of Directive 1999/5/EC and 2011/65/EU. The original of the conformity assessment can be found at www.jablotron.com - Technical Support section

Note: Although this product does not contain any harmful materials we suggest you return the product to the dealer or directly to the producer after use. For more detailed information visit www.jablotron.com.